

# M

## M40Series Narrow

# FEATURES



### Center-direct Injection Engine (E-CDIS)

All three of these M-Series narrow tractors are equipped with Kubota's revolutionary center-direct injection system engines. The E-CDIS engine offers a rare combination of more power, optimum durability and greater efficiency. It provides you with what you need to get the job done quicker, while still minding your budget. These engines also boast lower noise levels, which equate to less stress and fatigue, especially after a long day on the tractor.

### F8/R8 Transmission and 4-wheel Brakes

The Hydraulic Shuttle transmission is designed to keep you moving and productive with synchronized four speeds of the main shift and a high/low range. The main shift also allows you to shift "on the fly" for smooth operation. The 4-wheel brakes work together with our mechanical wet disc brake system to offer safe and effortless stops every time. When traveling in 2WD, and both brakes are applied, 4WD instantly engages for 4 wheel braking power.

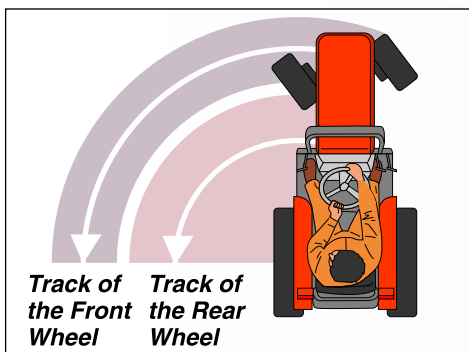

### Bevel Gear Front-Wheel Drive with Bi-Speed Turn

We've redesigned the front axle specifically for our M-Series narrow tractors. This bevel-gear front axle provides these tractors with greater strength, maneuverability and durability to handle their very specific demands. Kubota's exclusive Bi-Speed Turn feature rotates the front wheels at a rate of speed nearly twice that of the rear wheels whenever the front wheels exceed a turning angle of about 30 degrees. The result is a smoother, tighter turn, allowing you to turn into an adjacent crop row on your first attempt. This feature also helps to significantly reduce surface damage. For safety, the Bi-Speed turn feature is automatically cancelled when traveling at higher speeds.

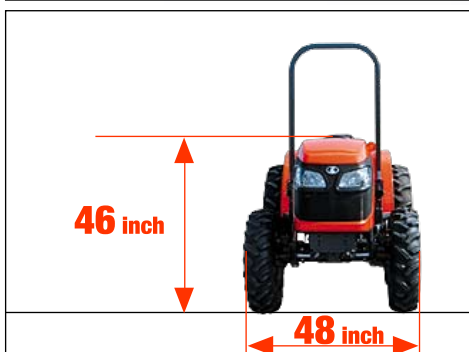

### Compact and Narrow Construction (Narrow)

Kubota has engineered these models specifically for those who work in vineyards, orchards or anywhere else that might require a narrow and compact tractor with M-Series power. With an overall width of just 48" with standard tires, you can work almost anywhere. To further ensure that these machines go where you want them, we've also rounded the standard fenders, placed the ROPS in the middle of the tractor, included standard foldable hazard lights and made certain that the operating levers are positioned so as not to interfere with low branches.

### Foldable\* Center ROPS

For your safety and convenience, a foldable center ROPS is standard equipment. It's perfect for traveling under areas with height restrictions, or parking your tractor in the garage. This ROPS may be folded down easily without tools.

\* There is no operator protection provided by the ROPS in the folded position. For optimal operator safety, the ROPS should be placed in the upright and locked position.



# M40Series Narrow



## FEATURES

### **PTO Lever Layout**

The PTO lever is located in an easy-to-access location, under the steering wheel. This layout was carefully considered to provide operator comfort and ease-of-use.

### **Legroom**

When operating a tractor, space comes at a premium. The M-Series neatly repositioned most operational levers to the right of the seat. This provides the operator with plenty of legroom and greater comfort.

### **Tilt Steering Wheel**

The steering wheel of the cab gets out of the way when the operator is mounting or dismounting the tractor. An easily-accessible pedal raises and lowers the wheel to the position you desire.